



# TABLE MUSA

Who would say that through a blade from a windmill could be obtained much of the urban and domestic furniture?

# SOSTYL AIR<sup>®</sup>

GIVE A SECOND LIFE TO THE SO CALLED EVIL WASTE OF ENERGY WIND POWER FOR ITS RECONVERSION INTO A WIDE RANGE OF PRODUCTS LIKE,

BENCHES, FLOWERPOTS, TABLES, CHAIRS, LAMPS...

ECOLOGICAL AND SUSTAINABLE



DESCRIPTION: Functional writing table. The wooden board comes from the inside of the wind blade

Measures*:	Height	85 cm
	Width	80 cm
	Length	150 cm
	Approximate measurements	

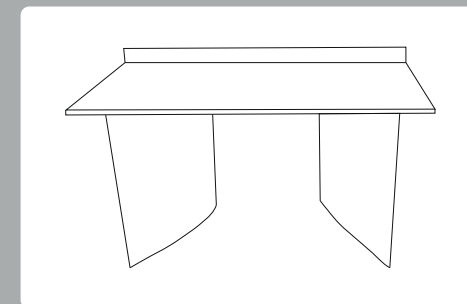

Colour: Basic presentation in white and black. The customer can customise the external colour of the table according to their needs, at a cost of 25€, with this option being free of charge for orders of 5 units or more. Sustainable production.

\*There is the option of of customised measurements

Ventos Metódicos Reciclagem LDA.  
Polígono Industrial da Lagoa. Rua das Cruzes, 484  
4950-850 Monção. Portugal

info@sostylair.eu  
Teléfono: +34 62686 86 30



# Table MUSA



REF: 0009

 **Measures\***

**Length: 150 cm**  
**Width: 80 cm**  
**Height: 85 cm**

 **Weight**

**30 Kg**

 **Paint Temperature**

**Max. 65°C**

 **Color**

**White**  
**Black**  
**Customised**

 **Content**

**1 Cover**  
**2 Legs**  
**4 Screws**

 **Packaging Measures**

**Length: 150 Cm**  
**Width: 80 cm**  
**Height: 45 cm**

 **Warranty**

**2 Years**

\*Approximate measurements

*Made with recycled materials. 95% sustainable.*



Polígono Industrial da Lagoa  
Rua das Cruzes, n° 484  
4950-850 Monção  
Portugal

 [www.ventosmetodicos.com](http://www.ventosmetodicos.com)  
 +351 258 099 691





# TABLE PUNTAIR

Who would say that through a blade from a windmill could be obtained much of the urban and domestic furniture?

**SOSTYL AIR**®

GIVE A SECOND LIFE TO THE SO CALLED EVIL WASTE OF ENERGY WIND POWER FOR ITS RECONVERSION INTO A WIDE RANGE OF PRODUCTS LIKE,

BENCHES, FLOWERPOTS, TABLES, CHAIRS, LAMPS...

ECOLOGICAL AND SUSTAINABLE



**DESCRIPCIÓN:** The essence of the wind blade, with a neat finish and beautiful aesthetics, is available in various sizes. The feet are made from the wind turbine's own material. The feet are made of wind turbine material. There is the option of customisation in metal, material or other materials.

Measures\*:

Height	80 cm
Width	70 to 80 cm
Length	250, 270, 300 or 340 cm

Approximate measurements

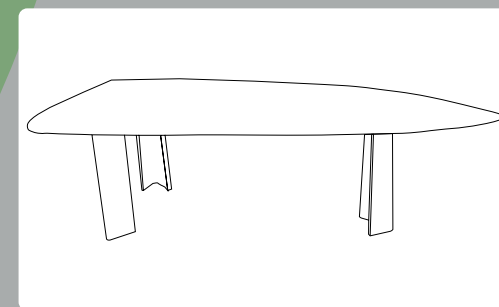

Colour: Basic presentation in white and black. The customer can customise the exterior colour of the table according to their needs, at a cost of 50€, this option is free of charge for orders of 5 units or more. Sustainable production

\*There is the option of of customised measurements

Ventos Metódicos Reciclagem LDA.  
Polígono Industrial da Lagoa. Rua das Cruzes, 484  
4950-850 Monção. Portugal

info@sostylair.eu

Teléfono: +34 62686 86 30



# Table PUNTAIR

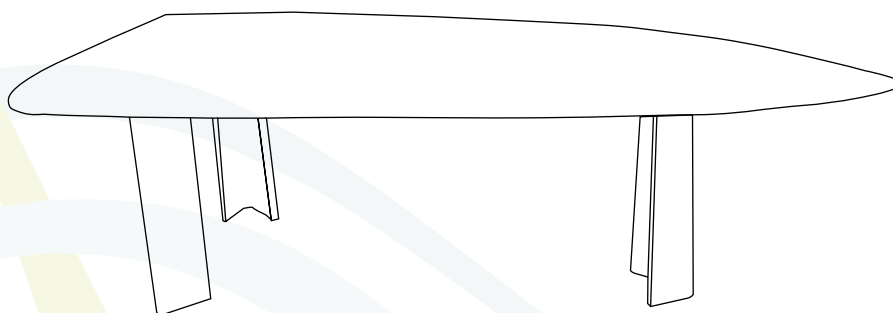

REF: 0010

## Measures\*

**Length: 250, 270, 300 or 340 cm**  
**Width: 70 to 80 cm**  
**Height: 80 cm**

## Weight

**90 Kg**

## Paint Temperature

**Max. 65°C**

## Color

**White**  
**Black**  
**Customised**

## Content

**1 Cover**  
**3 Legs**  
**9 Screws**

## Packaging Measures

**Length: 250, 270, 300 or 340 cm**  
**Width: 70 to 80 cm**  
**Height: 80 cm**

## Warranty

**2 Years**

\*Approximate measurements

*Made with recycled materials. 95% sustainable.*



Polígono Industrial da Lagoa  
Rua das Cruzes, n° 484  
4950-850 Monção  
Portugal

 [www.ventosmetodicos.com](http://www.ventosmetodicos.com)  
 +351 258 099 691





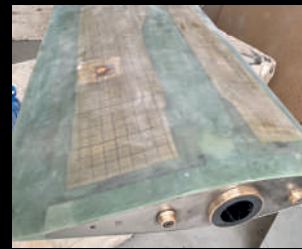

# TABLE BAR

Who would say that through a blade from a windmill could be obtained much of the urban and domestic furniture?



GIVE A SECOND LIFE TO THE SO CALLED EVIL WASTE OF ENERGY WIND POWER FOR ITS RECONVERSION INTO A WIDE RANGE OF PRODUCTS LIKE,

BENCHES, FLOWERPOTS, TABLES, CHAIRS, LAMPS...

ECOLOGICAL AND SUSTAINABLE



DESCRIPTION: The essence of the wind blade, with a neat finish and beautiful aesthetics, it is available in various sizes.

Measures*:	Height	110 cm
	Width	60 to 80 cm
	Length	100 to 250 cm
	Approximate measurements	

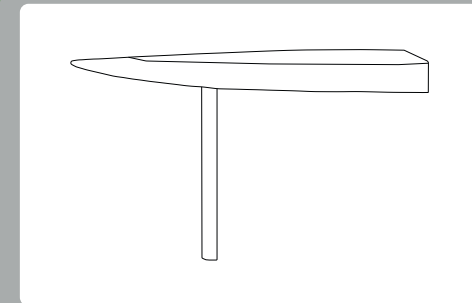

Colour: Basic presentation in white and black. The customer can customise the external colour of the table according to their needs, at a cost of 50€, with this option being free of charge for orders of 5 units or more. Sustainable production.

\*There is the option of of customised measurements

Ventos Metódicos Reciclagem LDA.  
Polígono Industrial da Lagoa. Rua das Cruzes, 484  
4950-850 Monção. Portugal

info@sostylair.eu  
Teléfono: +34 62686 86 30



# Table BAR

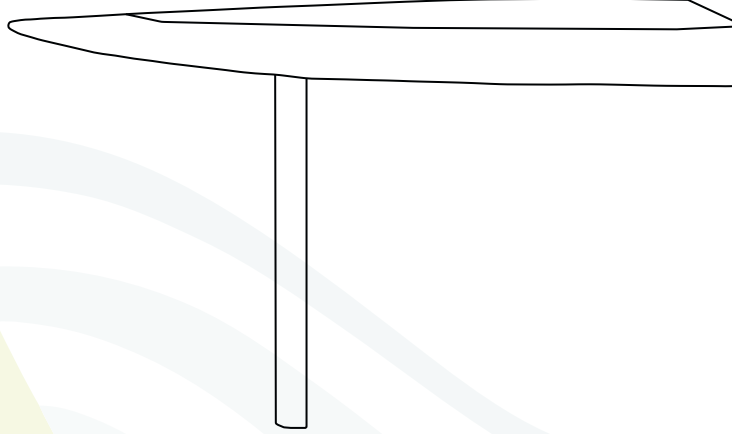

REF: 0011

## Measures \*

**Length: 100 to 250 cm**  
**Width: 60 to 80 cm**  
**Height: 110 cm**

## Weight

**90 Kg**

## Paint Temperature

**Max. 65°C**

## Color

**Blanco**  
**Negro**  
**Personalizado**

## Content

**1 Cover**  
**1 Leg**  
**2 Screws**

## Packaging Measures

**Length: 250 Cm**  
**Width: 85 cm**  
**Height: 40 cm**

## Warranty

**2 Years**

\*Approximate measurements

*Made with recycled materials. 95% sustainable.*



Polígono Industrial da Lagoa  
Rua das Cruzes, n° 484  
4950-850 Monção  
Portugal

 [www.ventosmetodicos.com](http://www.ventosmetodicos.com)  
 +351 258 099 691



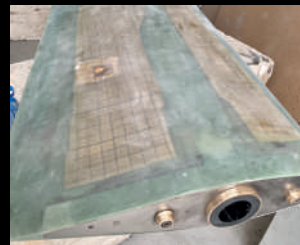

# TABLE HALL

Who would say that through a blade from a windmill could be obtained much of the urban and domestic furniture?

# SOSTYL AIR<sup>®</sup>

GIVE A SECOND LIFE TO THE SO CALLED EVIL WASTE OF ENERGY WIND POWER FOR ITS RECONVERSION INTO A WIDE RANGE OF PRODUCTS LIKE,

BENCHES, FLOWERPOTS, TABLES, CHAIRS, LAMPS...

ECOLOGICAL AND SUSTAINABLE



DESCRIPTION: The essence of the wind blade, with a carefully finished and beautiful and aesthetically pleasing, is available in various sizes. The feet are made from the wind turbine material itself. There is the option customisable in metal, material or other materials.

Measures*:	Height	50 cm
	Width	100 cm
	Length	300 cm

Approximate measurements

Colour: Basic presentation in white and black.

The customer can customise the external colour of the table according to their needs, at a cost of 50€, with this option being free of charge for orders of 5 units or more. Sustainable production.

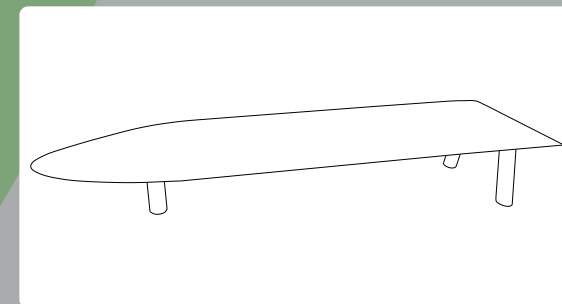

\*There is the option of customised measurements

Ventos Metódicos Reciclagem LDA.  
Polígono Industrial da Lagoa. Rua das Cruzes, 484  
4950-850 Monção. Portugal

info@sostylair.eu

Teléfono: +34 62686 86 30





# Table HALL

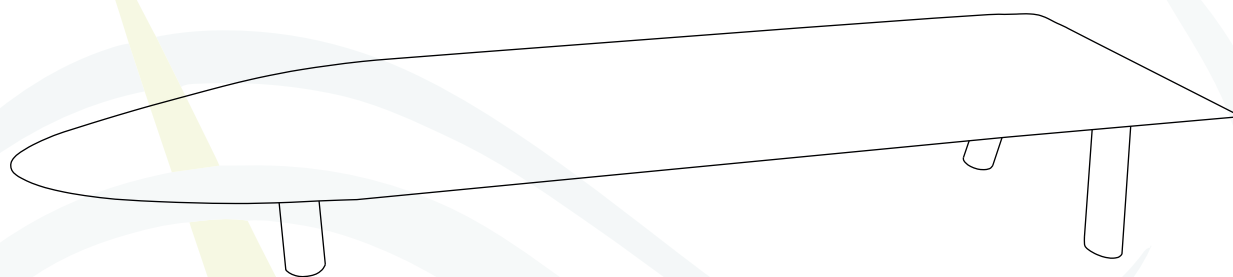

REF: 0012

## Measures\*

Length: 300 cm  
Width: 100 cm  
Height: 50 cm

## Weight

120 Kg

## Paint Temperature

Max. 65°C

## Color

White  
Black  
Customised

## Content

1 Cover  
3 Legs  
6 Screws

## Packaging Measures

Length: 300 Cm  
Width: 100 cm  
Height: 35 cm

## Warranty

2 Years

\*Approximate measurements

Made with recycled materials. 95% sustainable.



Poligono Industrial da Lagoa  
Rua das Cruzes, n° 484  
4950-850 Monção  
Portugal

[www.ventosmetodicos.com](http://www.ventosmetodicos.com)  
+351 258 099 691







# TABLE JÚLIO

Who would say that through a blade from a windmill could be obtained much of the urban and domestic furniture?

# SOSTYL AIR®

GIVE A SECOND LIFE TO THE SO CALLED EVIL WASTE OF ENERGY WIND POWER FOR ITS RECONVERSION INTO A WIDE RANGE OF PRODUCTS LIKE,

BENCHES, FLOWERPOTS, TABLES, CHAIRS, LAMPS...

ECOLOGICAL AND SUSTAINABLE



DESCRIPTION: Functional designer table of medium proportions. The wooden board comes from the inside of the wind blade.

Measures*:	Height	110 cm
	Width	45 cm
	Length	180 cm
	Approximate measurements	

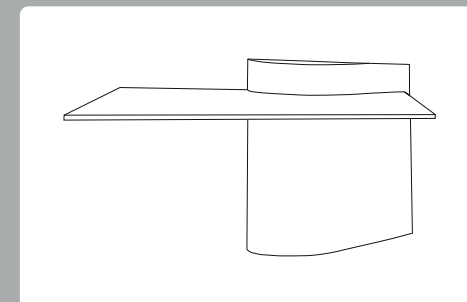

Colour: Basic presentation in white and black. The customer can customise the external colour of the table according to their needs, at a cost of 25€, with this option being free of charge for orders of 5 units or more. Sustainable production.

\*There is the option of of customised measurements

Ventos Metódicos Reciclagem LDA.  
Polígono Industrial da Lagoa. Rua das Cruzes, 484  
4950-850 Monção. Portugal

info@sostylair.eu  
Teléfono: +34 62686 86 30



# Table JÚLIO

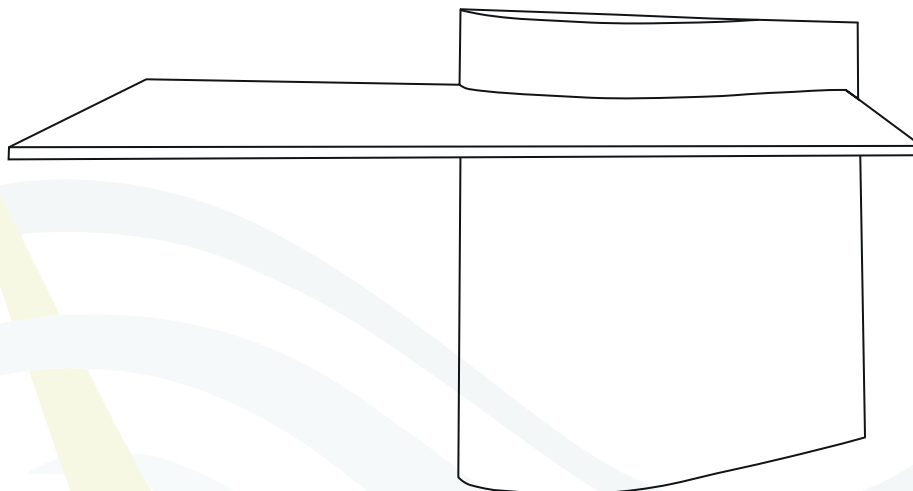

REF: 0013

 **Measures\***

**Length: 180 cm**  
**Width: 45 cm**  
**Height: 110 cm**

 **Weight**

**30 Kg**

 **Paint Temperature**

**Max. 65°C**

 **Color**

**White**  
**Black**  
**Customised**

 **Content**

**1 Cover**  
**1 Cover suport**

 **Packaging Measures**

**Length: 180 cm**  
**Width: 110 cm**  
**height: 40 cm**

 **Warranty**

**2 Years**

\*Approximate measurements

*Made with recycled materials. 95% sustainable.*



Poligono Industrial da Lagoa  
Rua das Cruzes, nº 484  
4950-850 Monção  
Portugal

 [www.ventosmetodicos.com](http://www.ventosmetodicos.com)  
 +351 258 099 691

